

REV. ZONE	DESCRIPTIONS	DWN BY	DATE

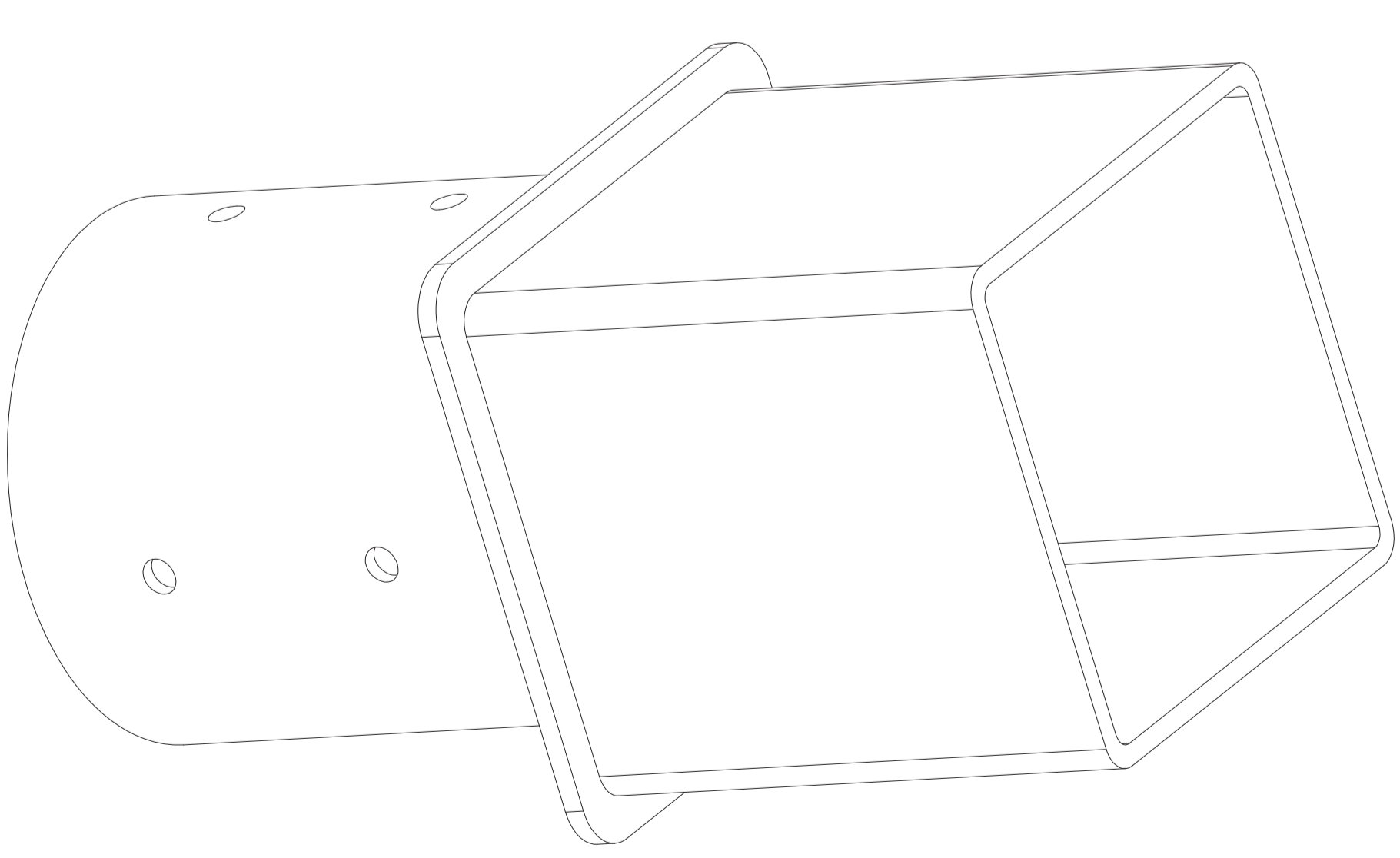
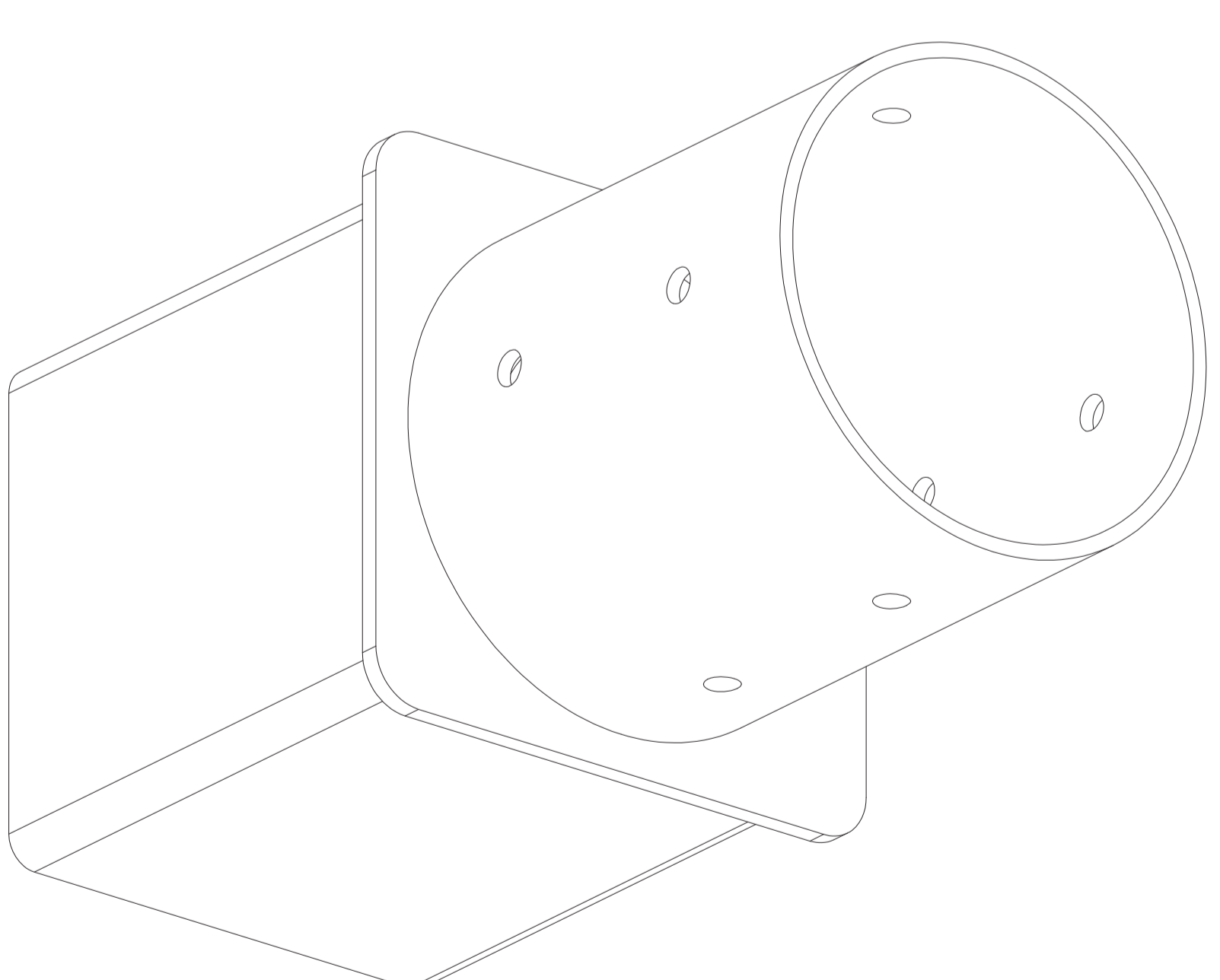
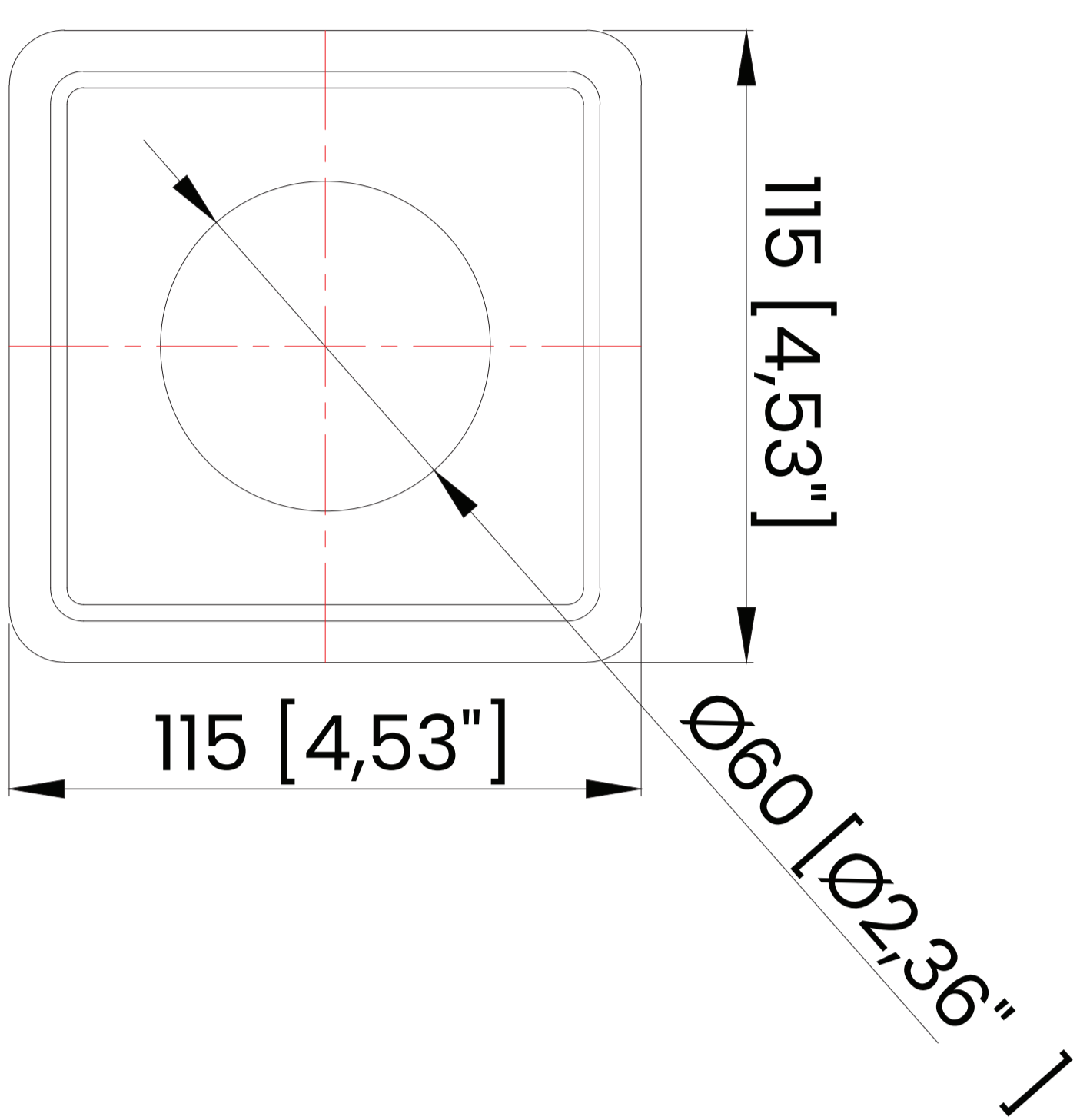
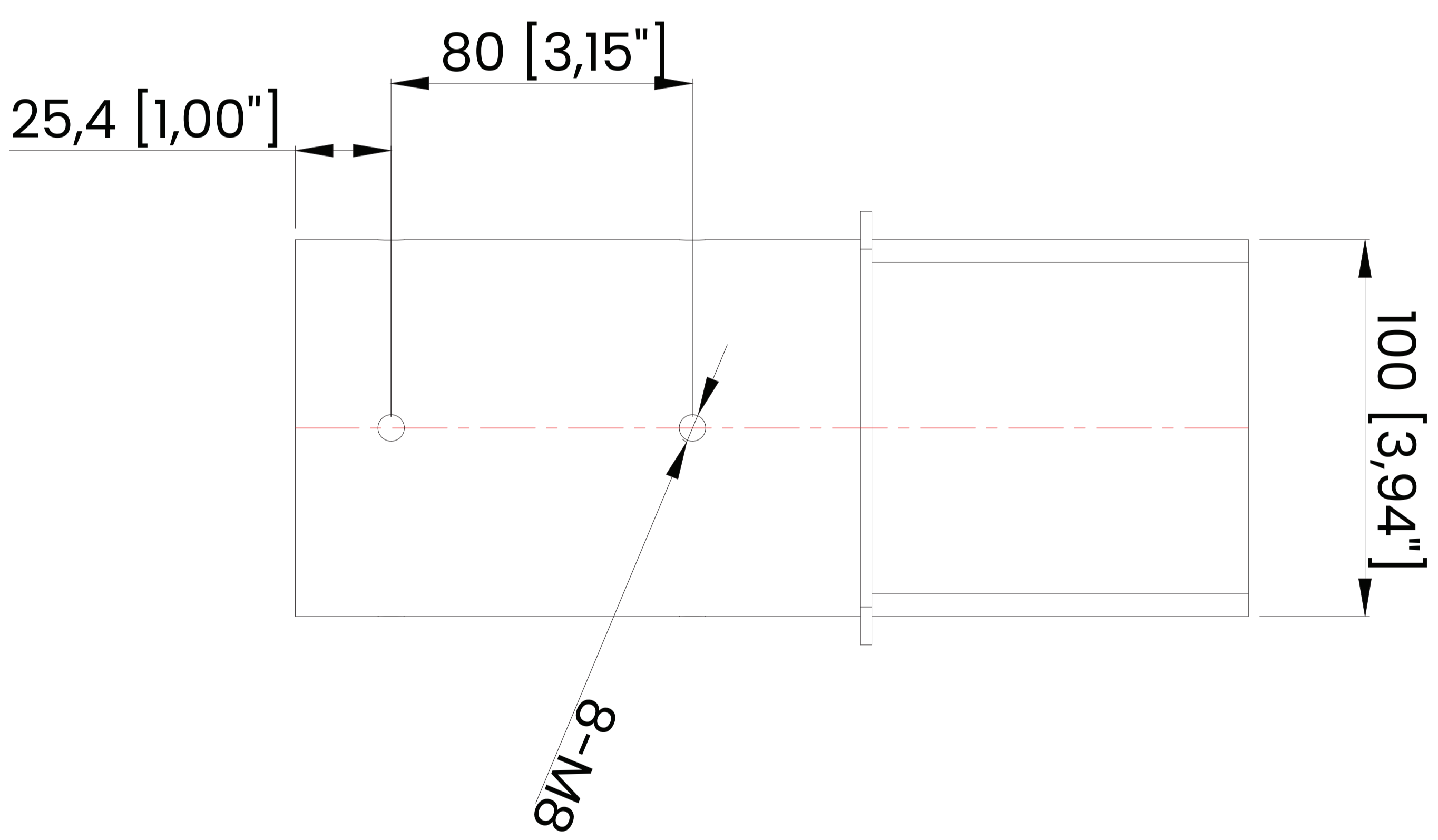
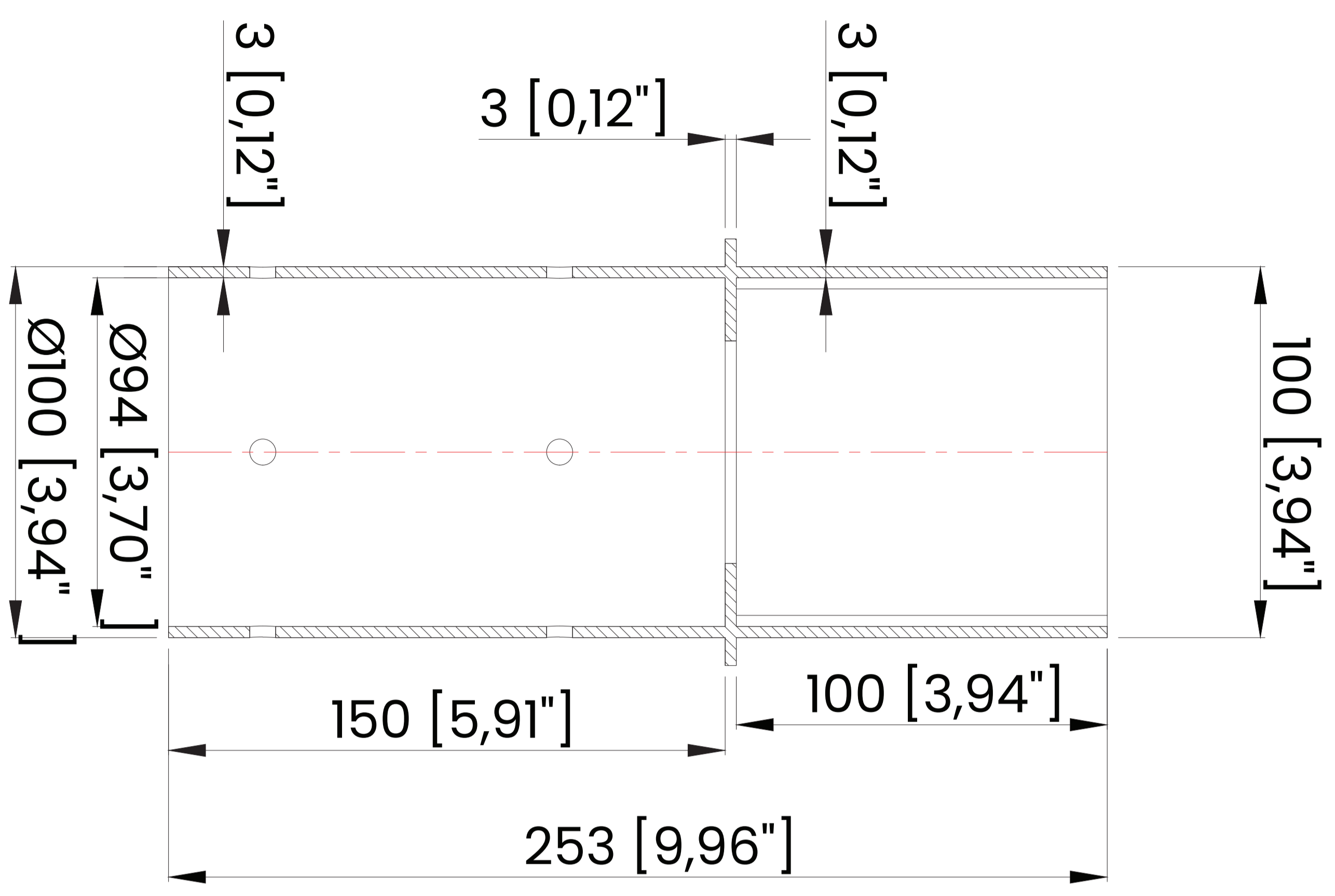

Net weight: 2.55Kg

DO NOT SCALE DRAWING		PROJECTION		V LIGHTS LLC LED LIGHTS	
TOLERANCE ALL DIM. ARE IN:mm		MODEL:		DATE:	
PART NAME:		CAD FILE:		S-PATH:	
MATERIAL: Iron		P-E FILE:		PART NO:	
CHKD.		DWN.		DWG. NO:	
APP.				FINISH:	
				REVISION:	
				REMARK:	
				PAGE OF	

	0	3	6	30	120	315
A	0.05	0.1	0.15	0.2	0.3	0.4
B	0.1	0.15	0.2	0.3	0.5	0.8
C	0.2	0.3	0.4	0.5	0.7	1.0
D	0.4	0.5	0.7	1.0	1.5	2.0

5

4

3

2

1

E

D

C

B

A

5

4

3

2

1

E

D

C

B

A

E