

DRILL DETAILS

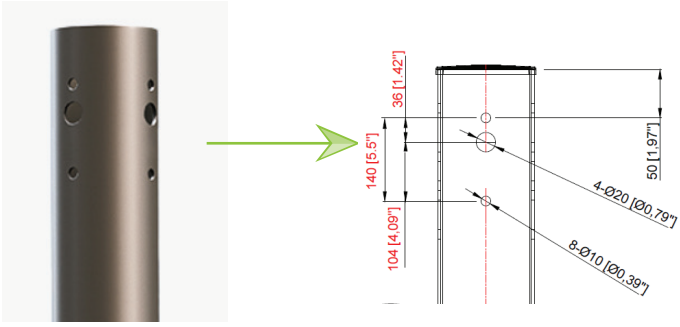

INTERNAL DIAGRAM

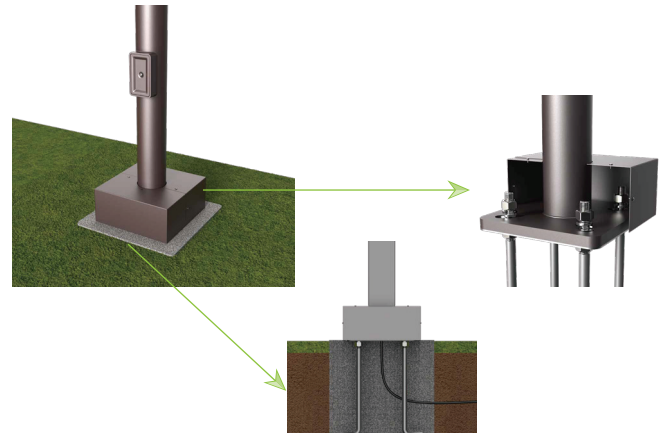

ANCHOR BOLE

4" Round

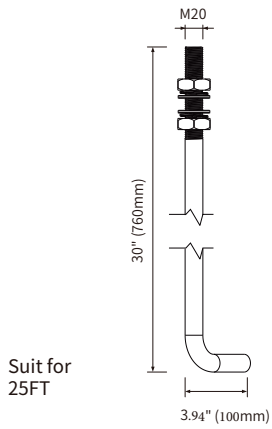

5" Tapered

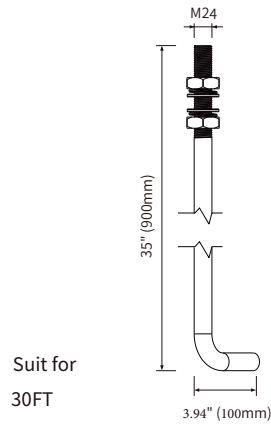

9" Tapered

